

SENTINEL[®]

CONNECTOR SYSTEMS



SPA-100 MODULAR PLUG APPLICATOR

Sentinel Connector Systems
1953 Stanton Street
York, Pa. 17404
Ph. 717-843-4240

SENTINEL
CONNECTOR
SYSTEMS

SPA-100
MACHINE

MANUAL

INTRODUCTION

Your SPA-100 machine comes to you fully equipped and set up to terminate the style of plug you have requested.

The SPA-100 will accommodate those small connector configurations such as 4 position, 4 contacts (4x4); 6 position, 2 contacts (2x6); 6 position, 4 contacts (4x6); and 6 position, 6 contacts (6x6). -Consult factory-

When set-up to do so, this machine will accommodate both small and large connectors alike, easy changeover from one to the other.

It is also electrically powered and does not require high-pressure airlines. It is are portable enough to be moved around easily and their straightforward design allows setup people to make changes in minutes.

All machines have full test capability with the cable tests performed as part of the termination procedure.

SPECIFICATIONS FOR SPA-100 MODEL CRIMPING MACHINES

Crimping machine portion

1. Usable connectors.....Recommended Sentinel Connectors
8x8, Cat 5 & Cat 6
(4x4, 2x6, 4x6, 6x6 Consult factory)
2. Function Crimping modular connectors onto cable
3. Power Source AC 115v, 60Hz, 5Amp
4. Driving System Single phase induction motor with gear head

Power consumption 90w
Rated current 0.75A
Starting current 1.9A
Gear head reduction ratio 30:1
Power.....1/10 H.P.
5. Mechanical power Punch pressure 130Kg
Punch stroke 16mm
6. Operation speed Machine cycle time 1.5 sec. (1.1 sec. of
Crimping + 0.5 sec. of electrical check under
10 ft. cable)
7. Emergency release function Reversing motor by "Rev" switch
8. Fuse 5 A
9. Size 5.5" (w) x 10 5/8 (h) x 13 1/8 (d)
10. Weight 40.4lbs

MANUAL FOR SPA-100 PRESS

I. Set-up

- A) Refer to page 6 for a pictorial view while following instructions.
- B) Plug press into the wall outlet 110 volts.
- C) Plug cable tester into 110 volts outlet.
- D) Attach cables (supplied) to press and cable tester as labeled.
- E) Select proper combination of switches on press.
 - 1) "Auto/Hand" (on press)
 - 2) "Double/Single" (on press)
 - 3) With a "known good cable" set-up a signature (on tester).

II. Ready to run

With the signature cable, insert into the nest(s). When the plug reaches proper depth, a micro switch in rear of nest actuates a single rotation of the press. When a single plug is required, only the left nest can be utilized.

CAUTION: When using both nests, make sure the selector switch is on double!

After ram on press has returned to top position, maintain the position of the plugs in the nest to insure an accurate reading on the tester. The plugs in the nests will actuate a micro switch to cycle machine, (if plug is removed and reinserted it will cycle again). When the ram is at its top position the test wires are making contact with the gold pins in the plugs, this will allow the tester to check continuity, shorts and correct polarity of plugs to wire. This test will remain active as long as plugs remain in the nests. Once the plug moves away from the micro switch in rear of nest, the machine resets itself to begin a new termination.

III. Adjustments

A) Nests

Both nests are in a fixed position and cannot be adjusted. However, They can be removed and replaced with other nests allowing termination of various Sentinel Connector Systems connectors.

- 1) The nests are equipped with two ball vilers that seat the connector into the nest securely. At times it may be necessary to remove these and replace them with new, when doing this please be sure not to over tighten as to damage the connector.

B) Punch holder assembly

The punches can also be adjusted as a unit or individually.

To move punches as a unit, loosen the two cap screws in the front of the head (item #65, page 18), move the head up or down using the screw on top (item #64 page 13) for adjusting, and retighten screws when proper position is located.

C) Punches

- 1) In order to make individual adjustments of the punches, there are small slotted screws on the top (item #60 page 17) of punch holder assembly. To make an adjustment first loosen screw (item #69 page 17) in front and the set screw on the side of punch holder assembly (item #61 page 17). Make the desired adjustments (NOTE: one complete turn of #60 screw is equivalent to .020 or 5mm). When the movement is made, push tooling up while lightly snugging the set screws on the side (item #61); then tighten the screws in front (item #69).
- 2) Any adjustment left to right can be made if necessary by loosening the screws at (item #66) adjustment required can be made by adjusting the proper tool unit in direction desired. (see step 3 for a detailed description of how to make alignment).
- 3) Try this when lining up connector to punch. Remove the two punches on the side needing adjustment (left or right). Leave the contact punch installed, being held by set screw on the side of the unit. Now place a pre-inserted connector into the nest and jog the ram down just above the connector. With a small magnifying glass you will be able to see which way the tools need to move in relationship to the connector. You will now be able to make this adjustment. Loosen the proper bolts that move this unit and adjust. Retighten the bolts and return ram to its top position. Replace the punches and retighten them.
- 4) Strip the jacket cord, trim the conductor to length, place a connector on both ends of cord and insert the plugs into the nest.
- 5) When a cycle is made the test fingers will remain on the connector and test for shorts, continuity and miswires. If the product is ok and meets the desired signature, the tester will display a "good reading".
- 6) If there is a short or other problem, a tone will be heard and "error" will be displayed on the screen. Test fingers will stay down, touching the contacts, until at least one of the plugs has been removed from the nest, deactivating the micro switch.
- 7) If for some reason the ram does not return to its original position after crimping, turn the switch (labeled rev) on to return the ram manually. When ram is at the top, turn rev switch off before.

BASIC MACHINE

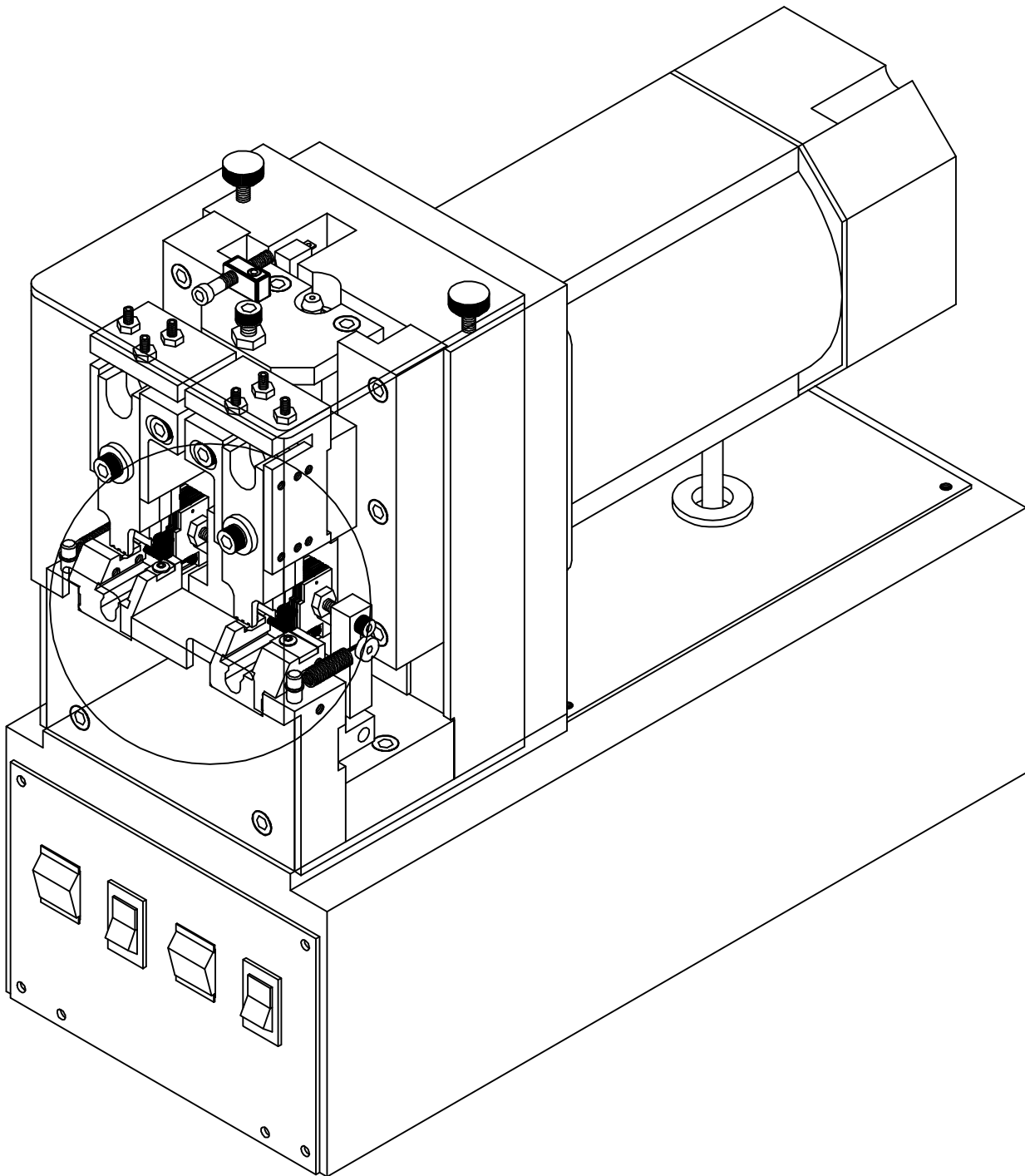

MACHINE AND TESTER SET-UP

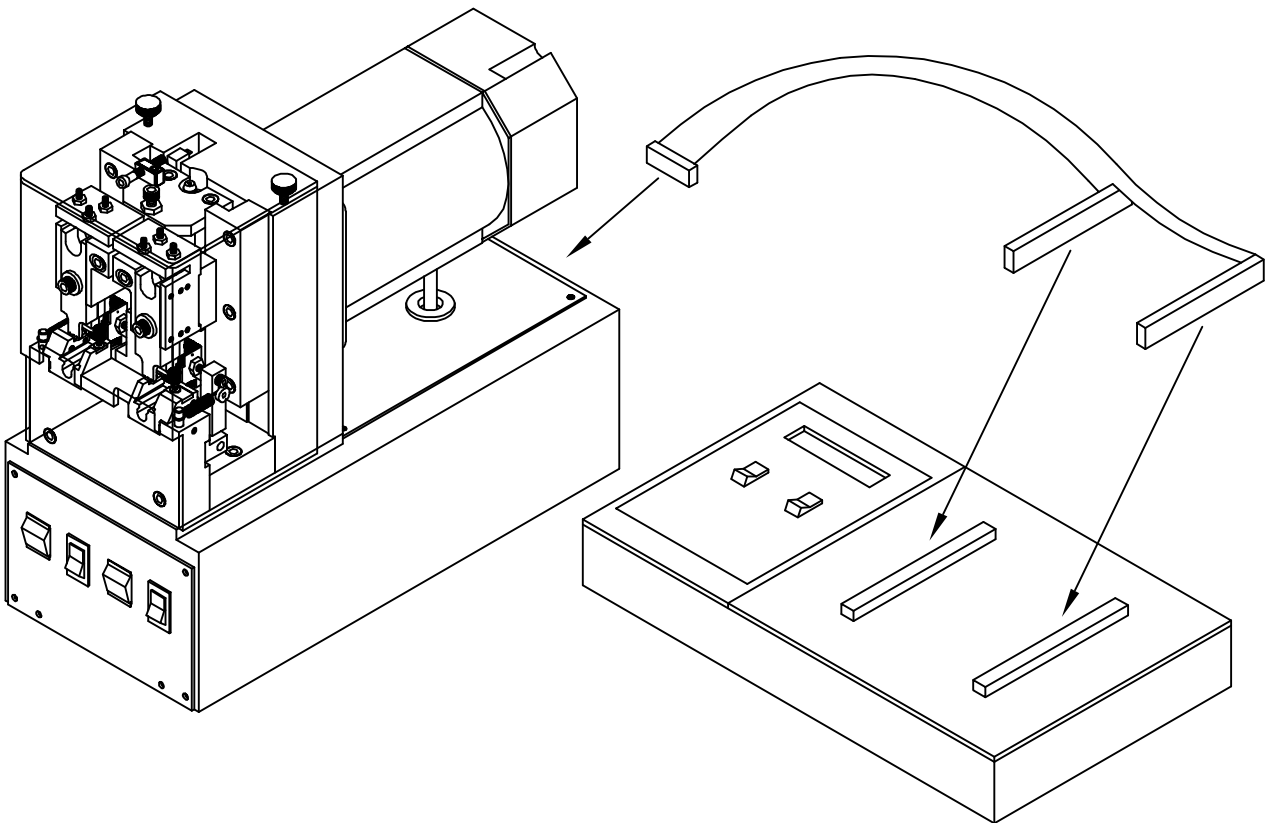

TERMINATION INSTRUCTIONS

These instructions are intended for use with the SPA-100 in conjunction with Sentinel Connectors modular plugs.

This product comes to you in single assemblies with contacts pre-inserted. Please refer to product manual for details on determining which of Sentinel's plugs will work the best for your application. Any further help may be obtained by contacting Sentinel direct and obtaining the proper guides.

Once you have determined which combination is best suited, strip the cable back far enough to allow the individual conductors to be inserted into the plug while also maintaining the outer jacket positioned under the jacket lock on the plug. Position the conductors, as desired, and insert them into the plug, making sure the conductors are securely positioned against the front of the plastic, to ensure the contacts penetrate properly.

After preparing cables with connectors, you are ready for termination. If only one plug is required to be terminated, switch machine to single. If both are desired, switch the button to double. This will allow you to properly align both connectors before the ram cycles down. After the ram completes the cycle, (keeping the plugs positioned in the nests) the test leads will come down, testing for continuity, shorts and opens. If the tested cable is defective, the tester will indicate exactly what the defect is. For further instructions on the tester, refer to the tester manual provided.

Once the cable is completed, a contact height check is necessary to maintain compliance with FCC, which is $.237 \pm .005$ from the bottom of the plug base (not including the tab) to the top of the contacts. This is roughly $.023$ from the top of the plug to the contacts at a nominal tolerance.

The tooling can be replaced relatively simply and quickly for short down time. Each tool can be adjusted individually or as a unit depending on what the need is.

The machine can be adjusted manually by removing motor guard to obtain access. Then turn the power off and rotate the fan in the direction desired (the ram will go up or down depending on the direction fan is turned clockwise or counter clockwise). Rotate the motor until ram comes down to a plug inserted into the nest for any adjustment necessary (the contacts in the plug should align with the contacts that do the driving). After making the adjustment, continue rotating the motor either way until the ram reaches the top and makes contact with the micro switch.

RECEIVING INSPECTION

This machine has been thoroughly inspected before leaving our facility. This provides the assurance that the machine produces good termination and Is ready to use. However, the following points should be reviewed to verify that no problems have occurred during shipment.

1. Carefully uncrate the machine and place it on a sturdy bench and examine it against the report sent with machine.
2. Inspect the entire machine for evidence of damage that may have occurred during transit. If in fact the machine shows signs of damage, contact Sentinel Connector Systems, Inc. immediately.
3. Check all components to be certain they are secure. Don't operate machine until all loose tooling has been tightened down safely.
4. Please maintain the crate the machine has been delivered. In the event the machine has need of repairs or lease if terminated the machine must be sent back in its original crate. This is to maintain proper protection of the machine from any shipping damage. Your help in this manner is greatly appreciated.
- 5.

MACHINE & GUARD ASSEMBLY

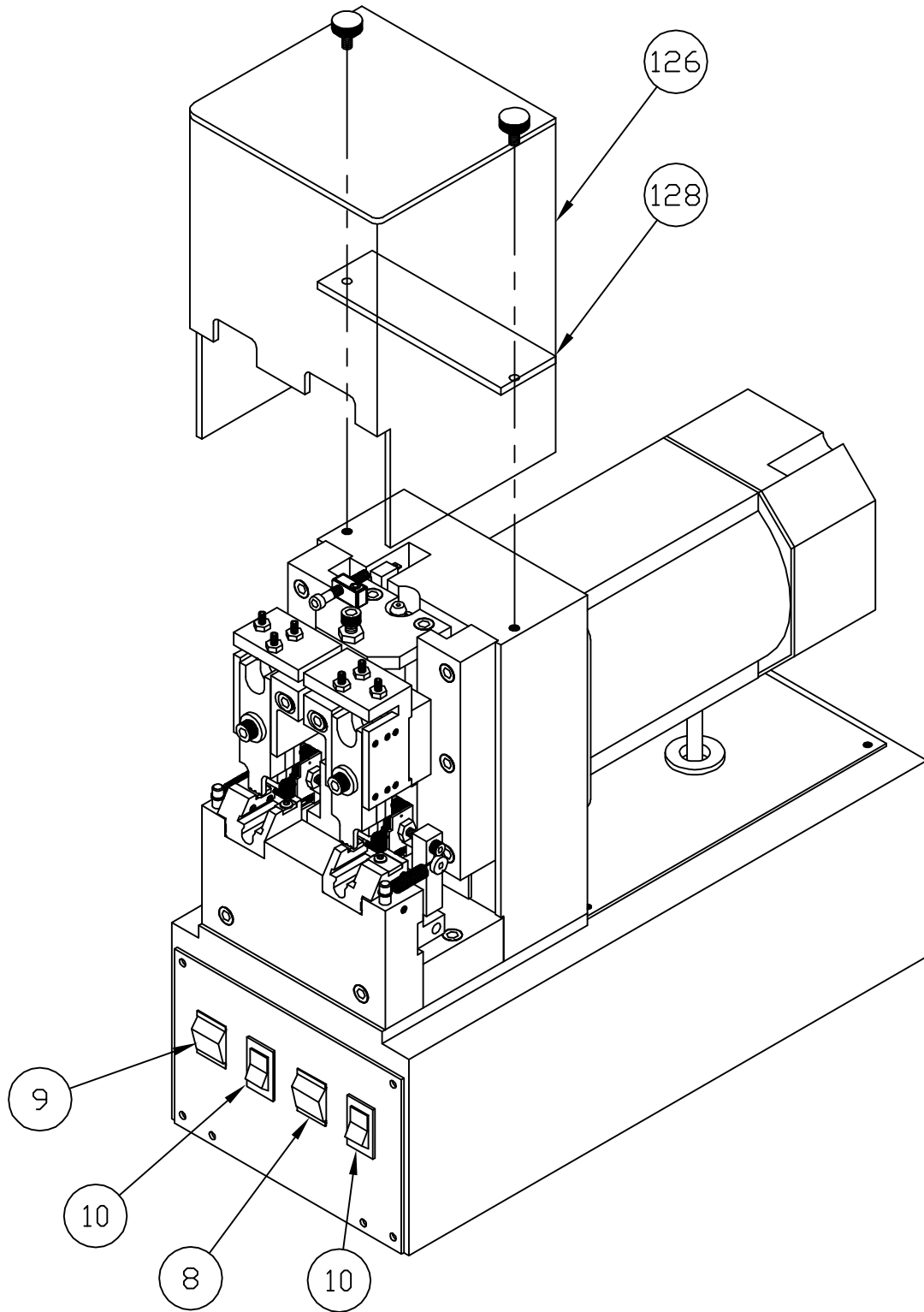

MACHINE BASE & PANELS ASSEMBLY

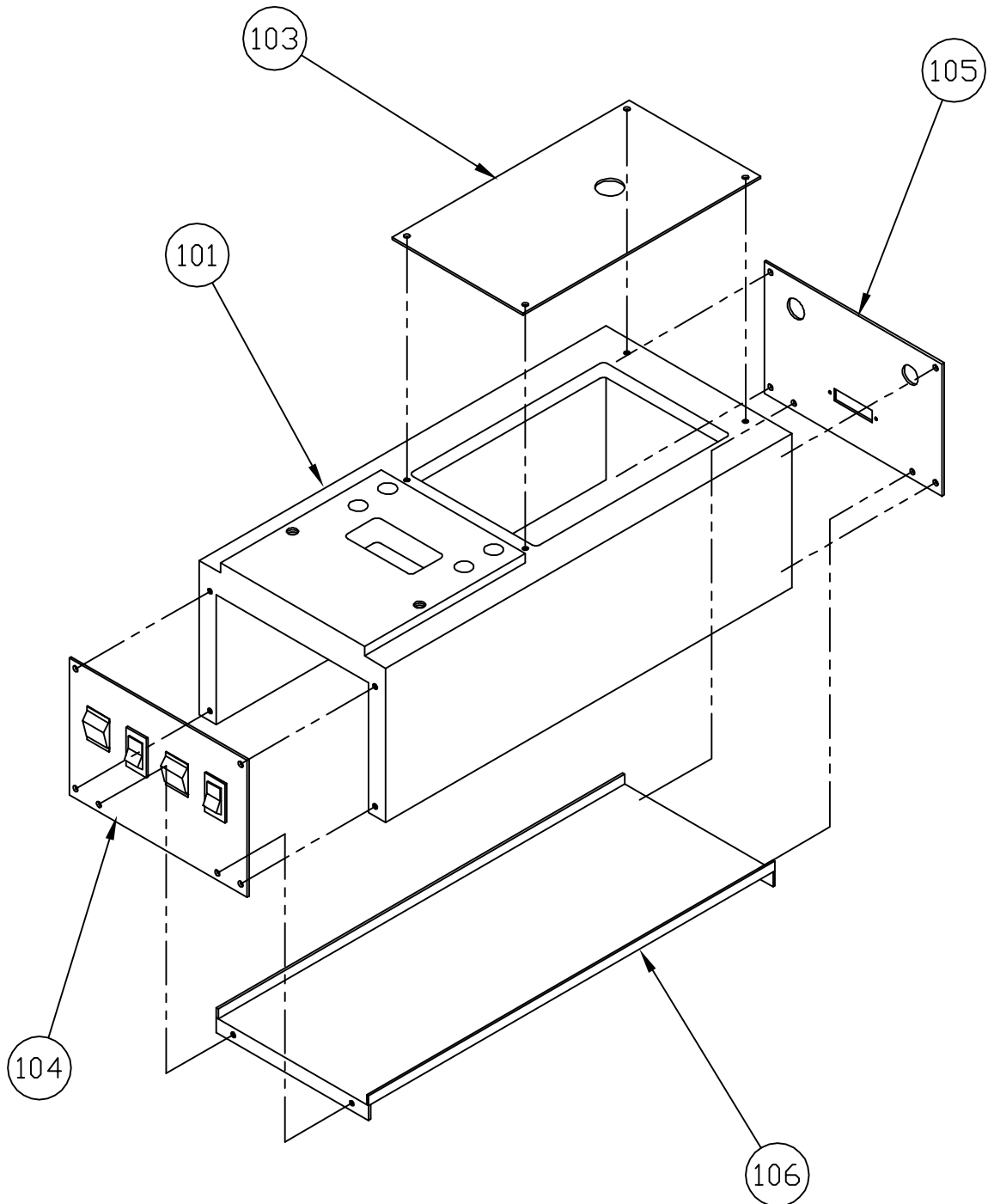

MOTOR AND TOOL SLIDE ASSEMBLY

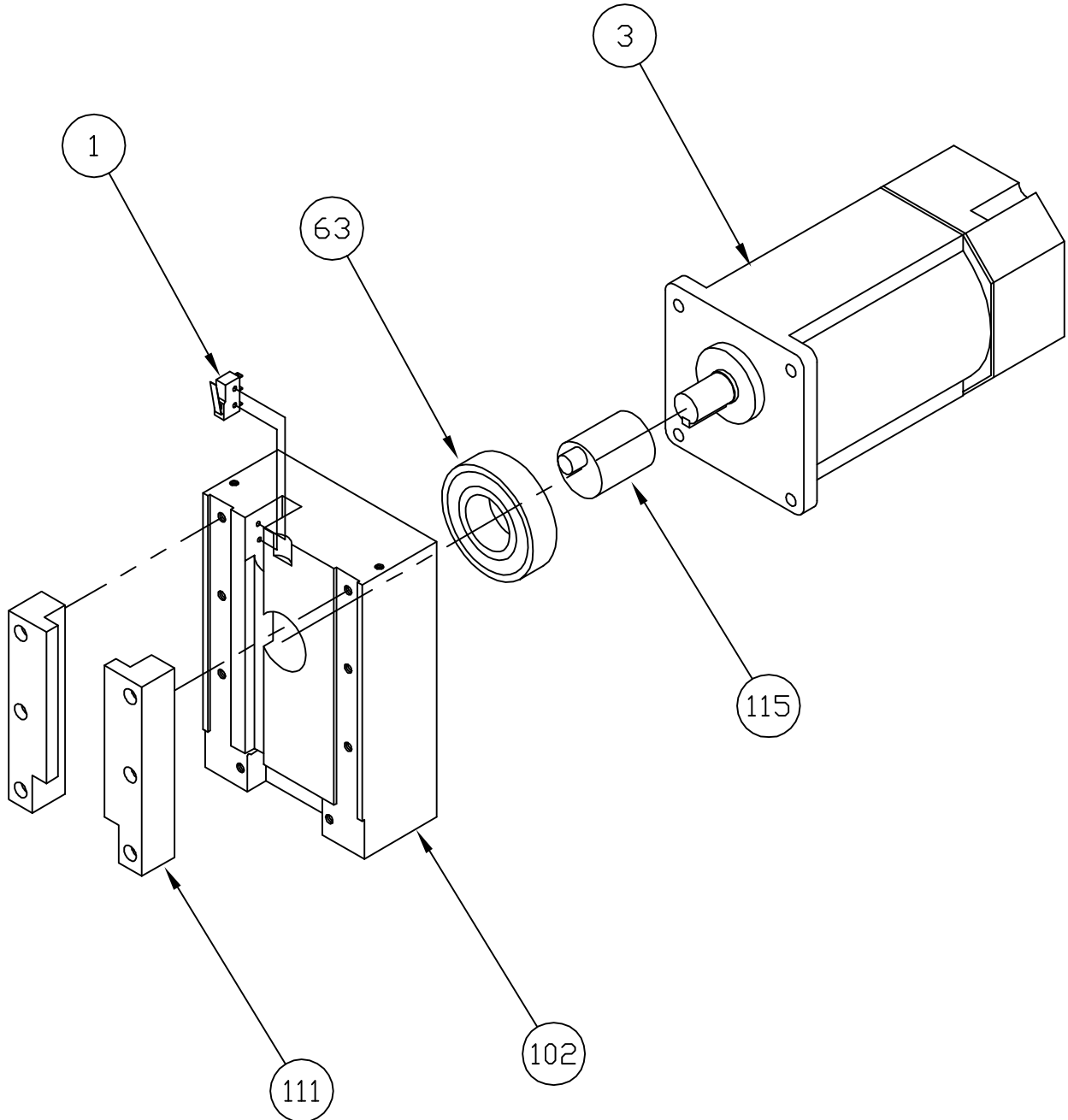

TOOL SLIDE AND PUNCH HOLDERS

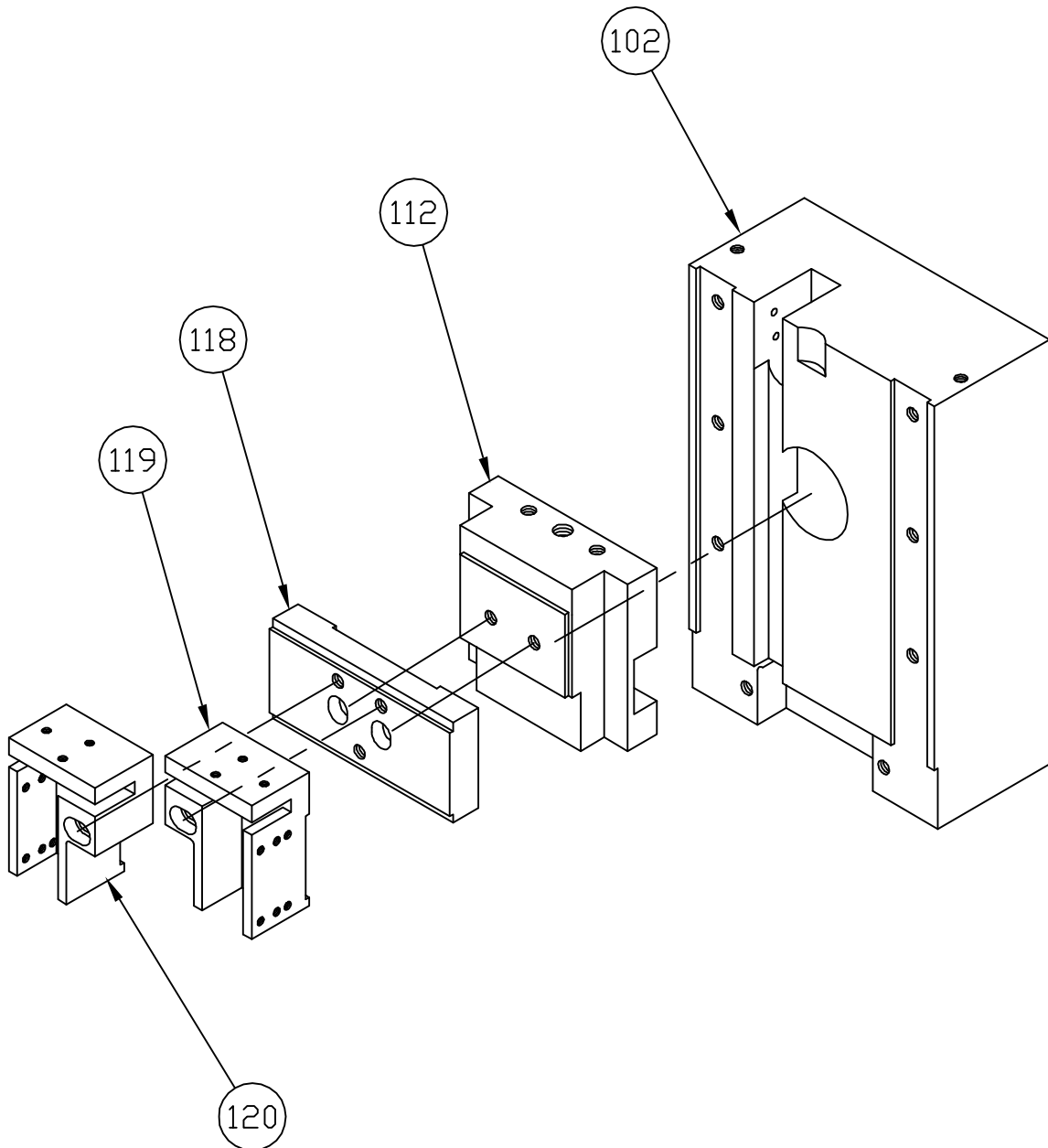

RAM SLIDE ASSEMBLY

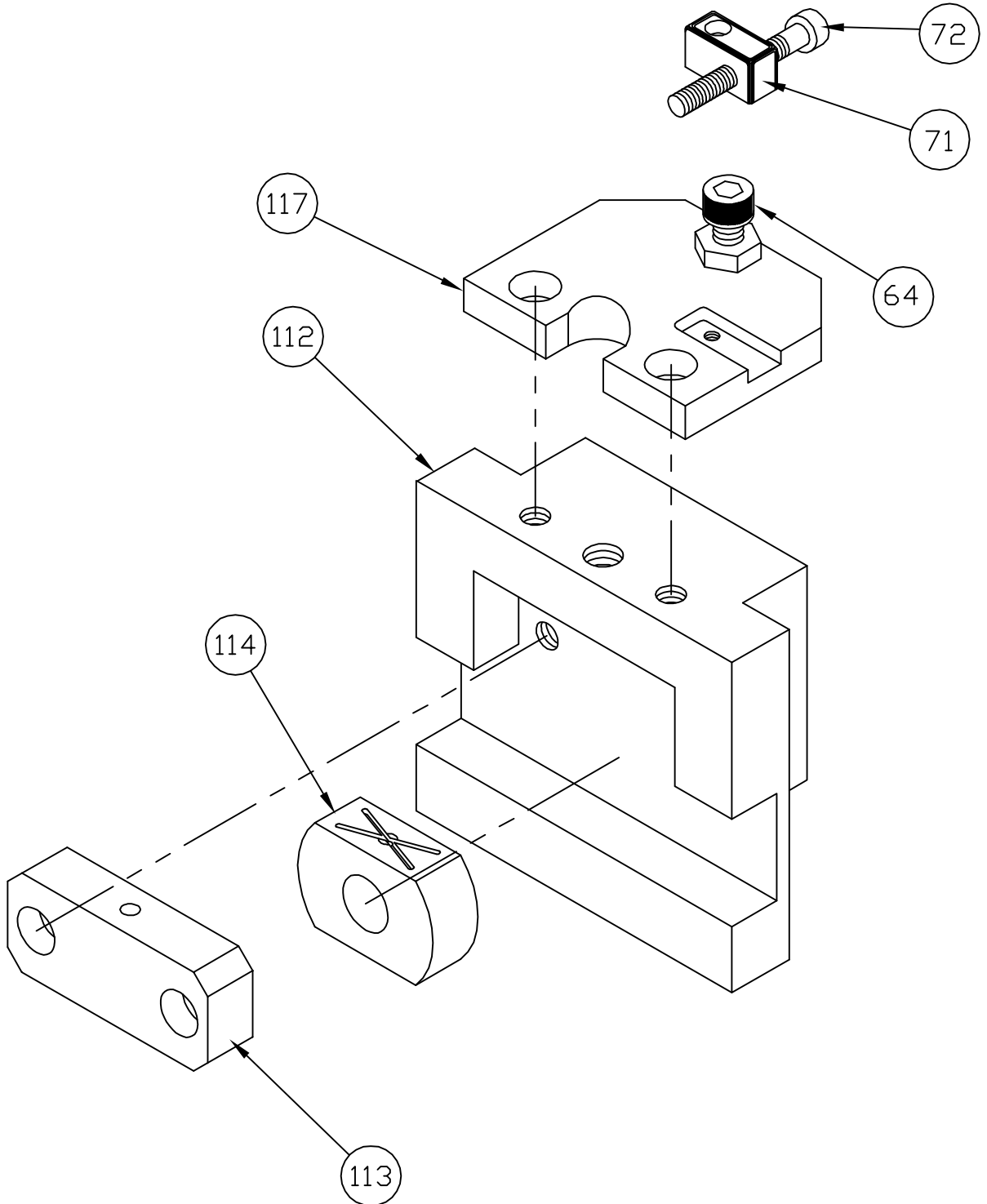

NEST ASSEMBLY (CLOSE-UP)

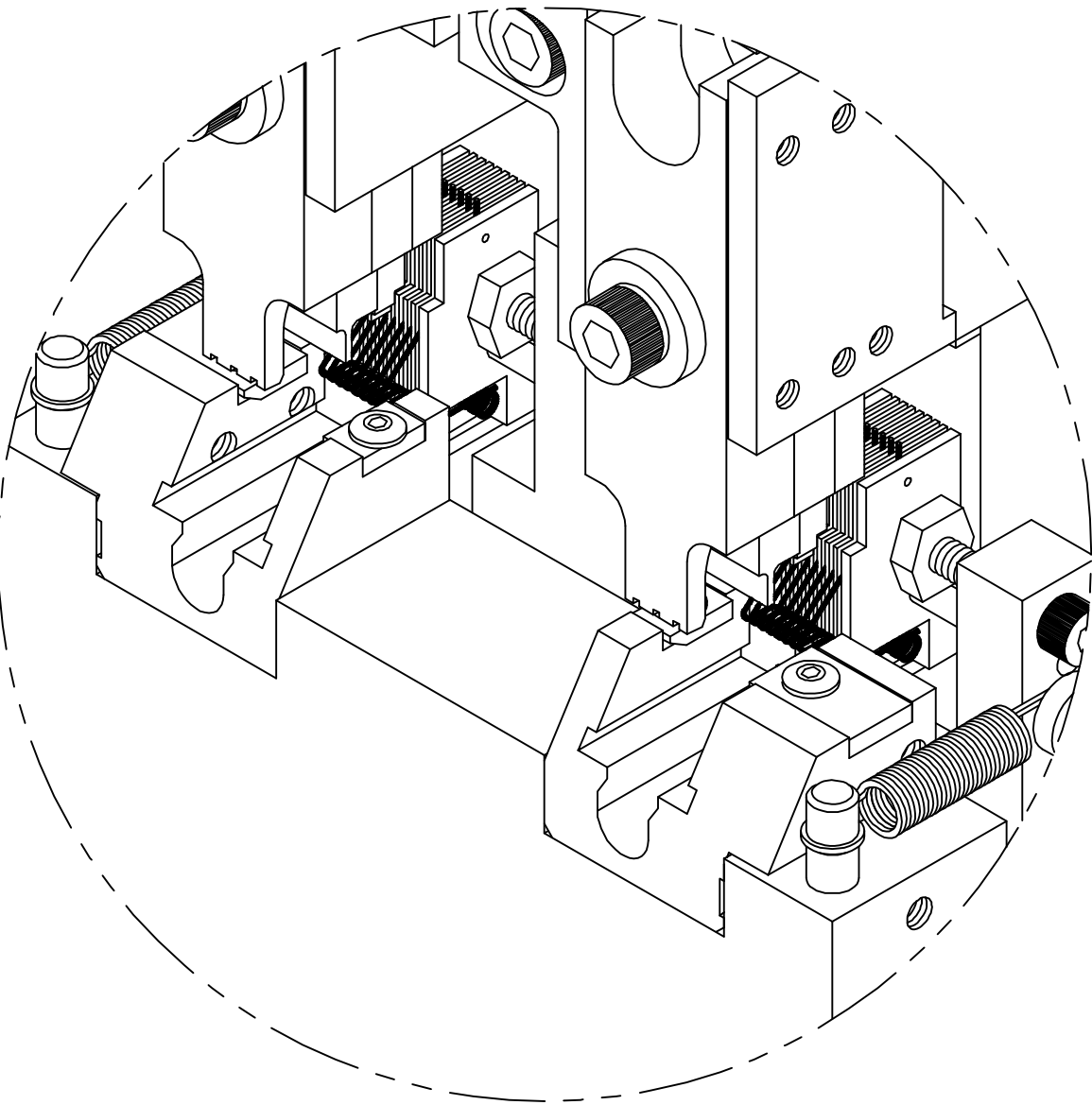

NEST BLOCK INCLUDING NESTS

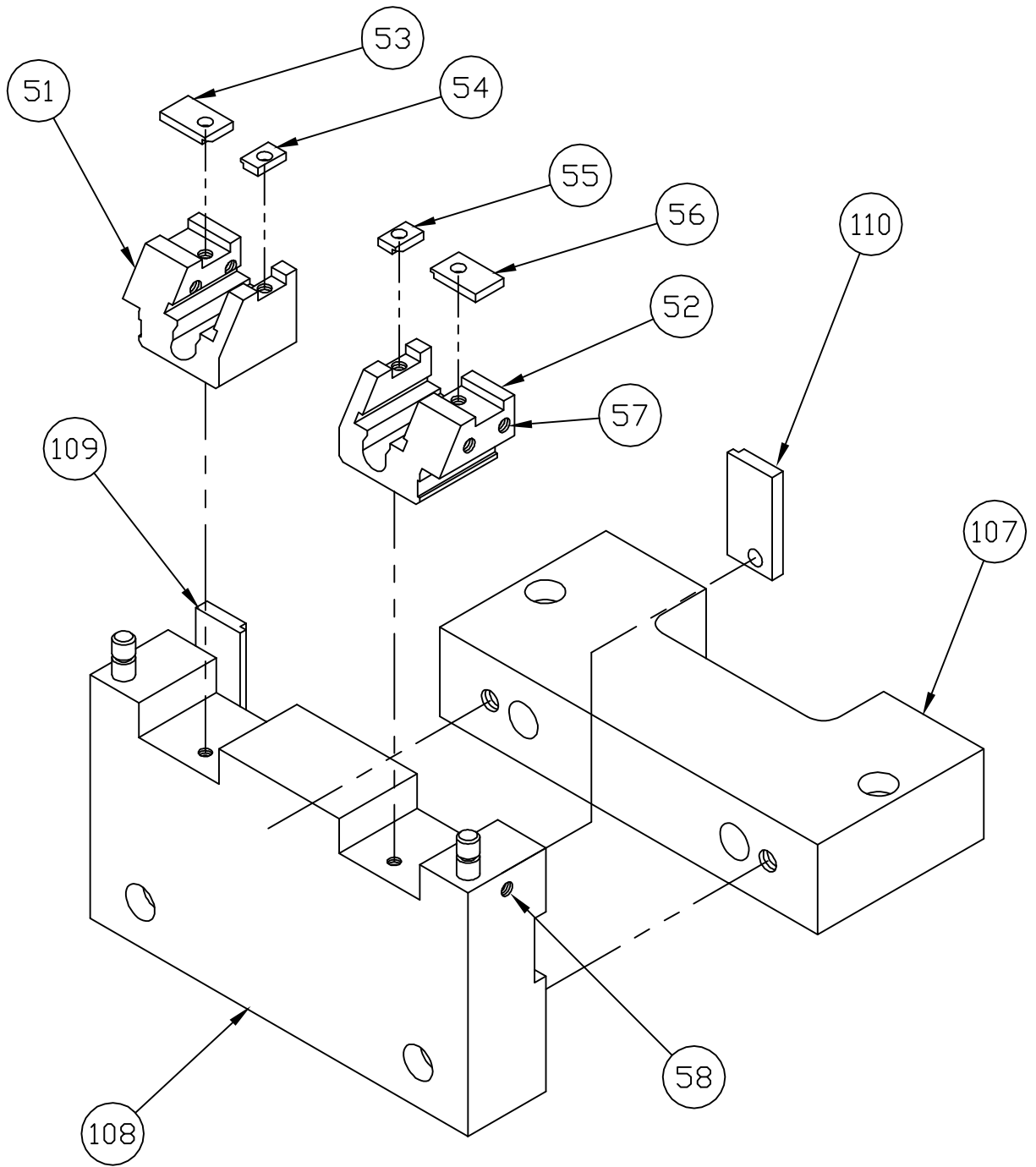

MICRO-SWITCH & NEST STOP ASSEMBLY

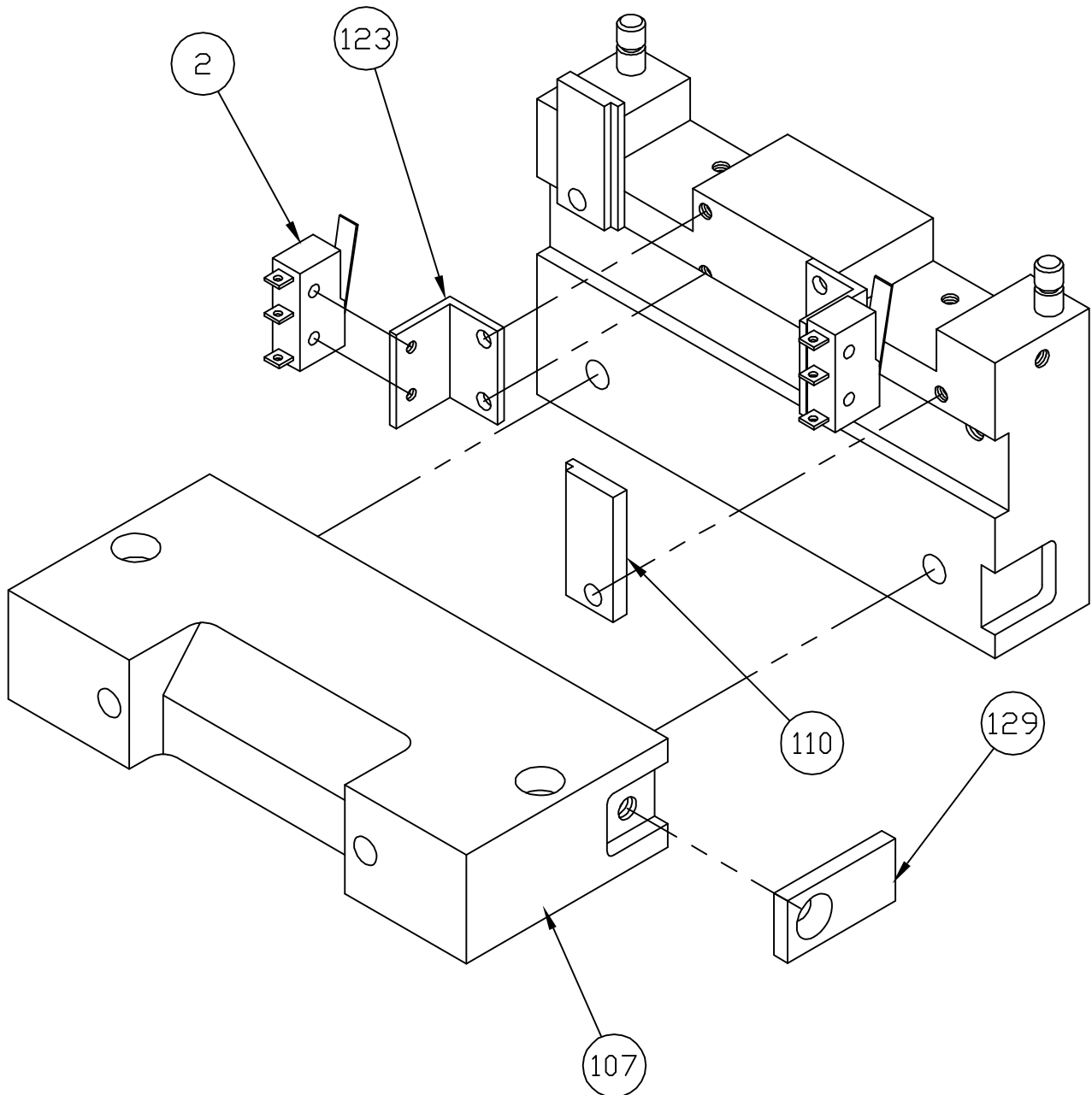

PUNCH HOLDER ASSEMBLY (8 POSITION)

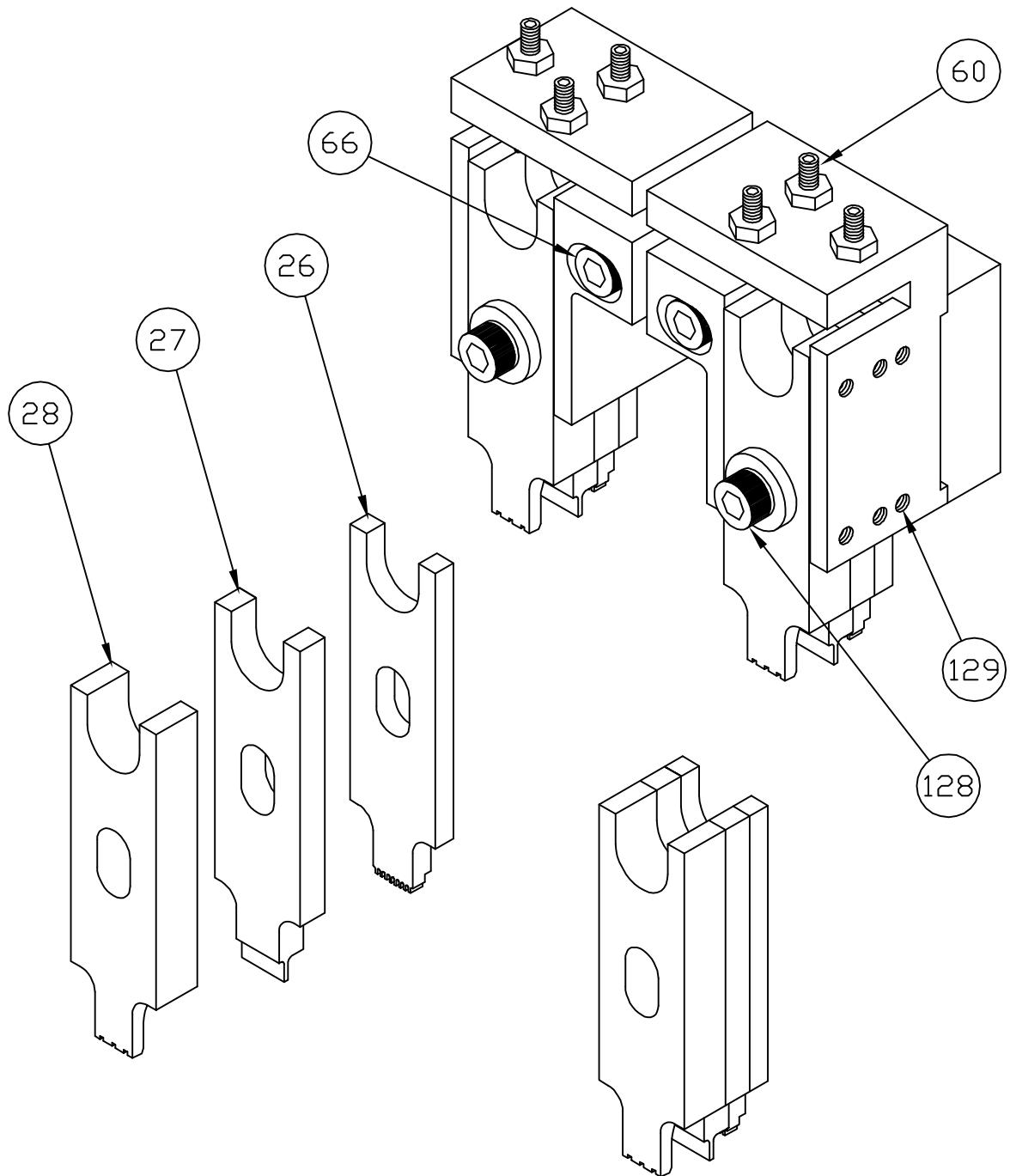

CAM & ADJUSTMENT ASSEMBLY

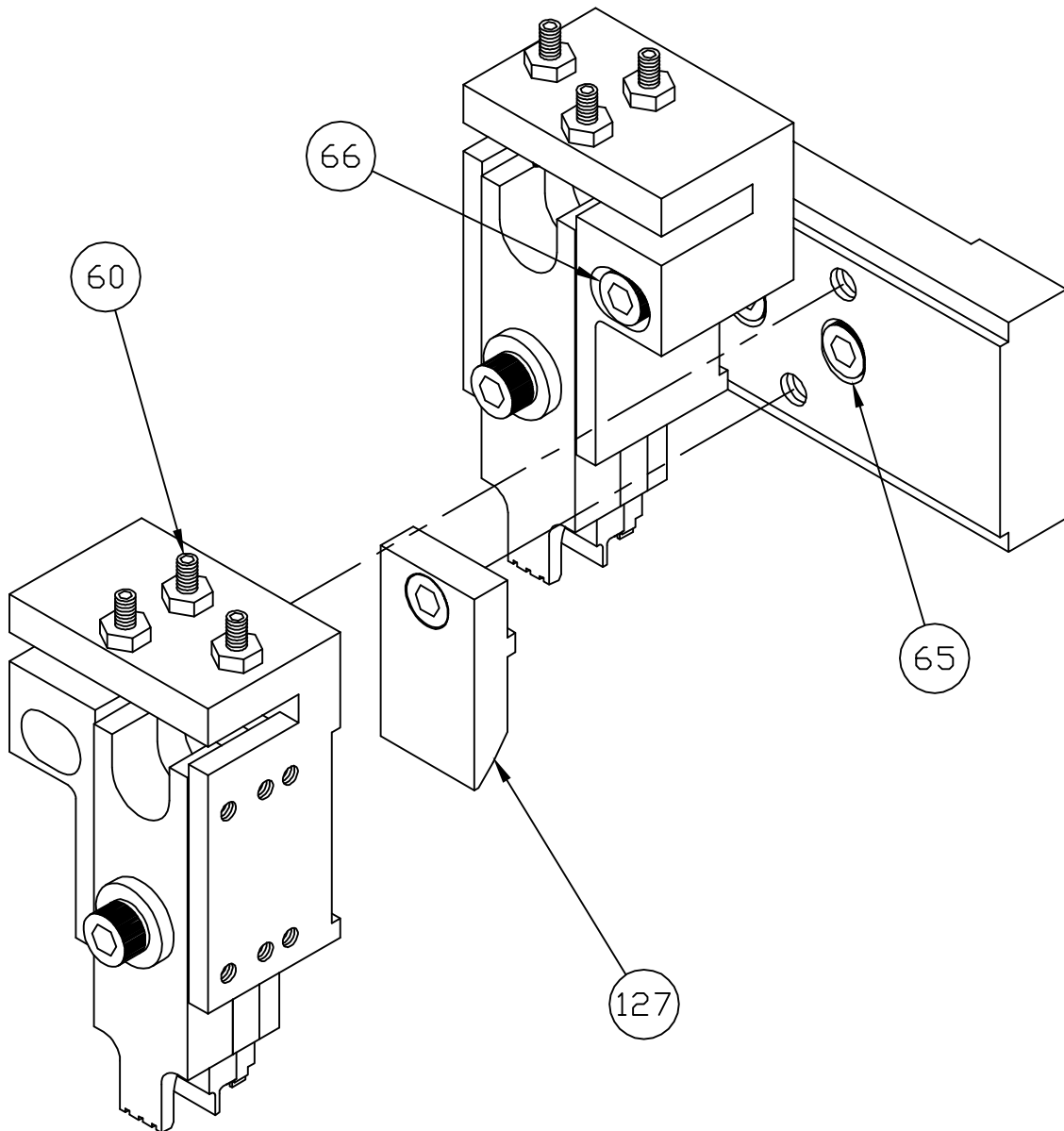

TEST ASSEMBLY

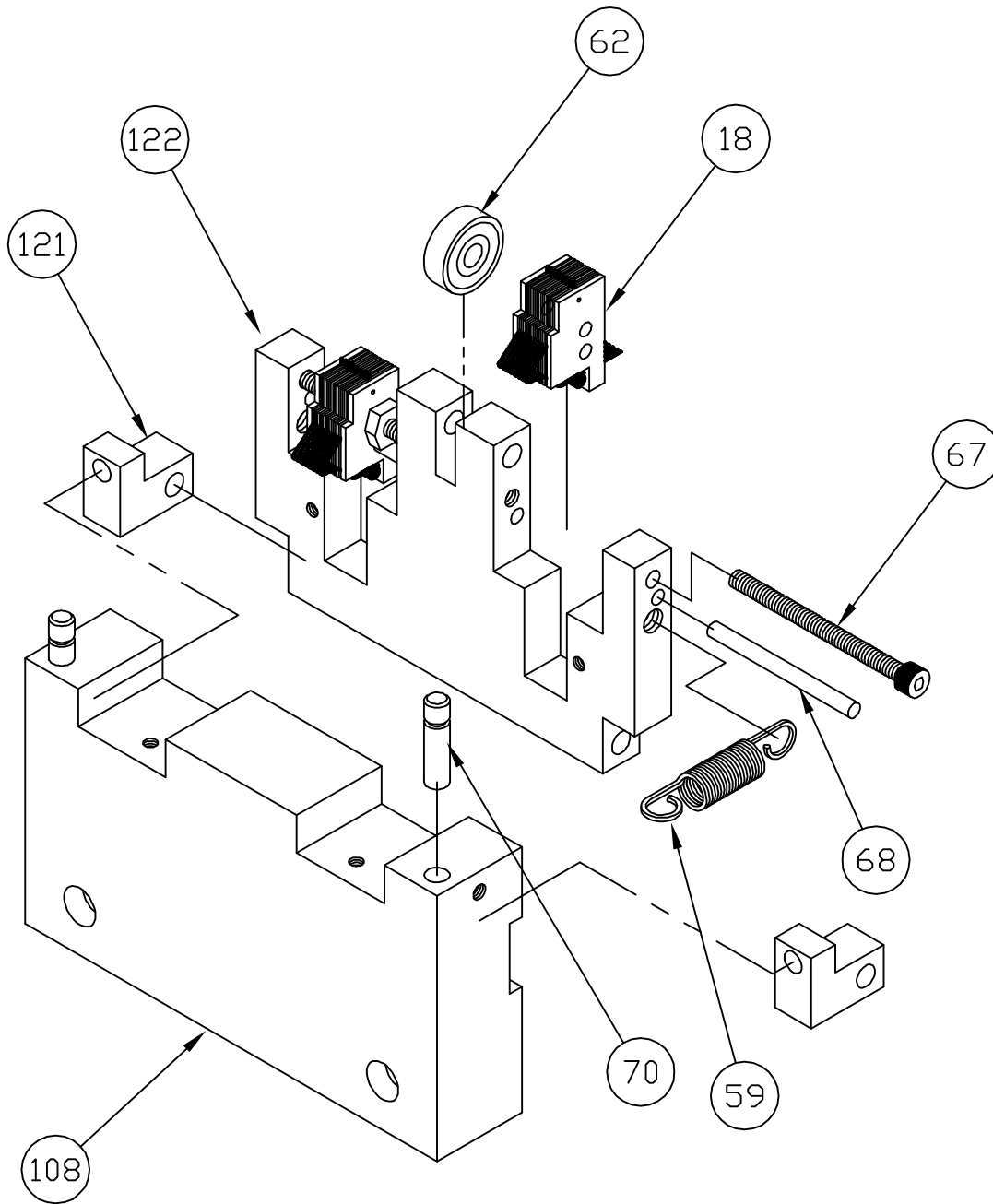

TEST BLOCK ASSEMBLY

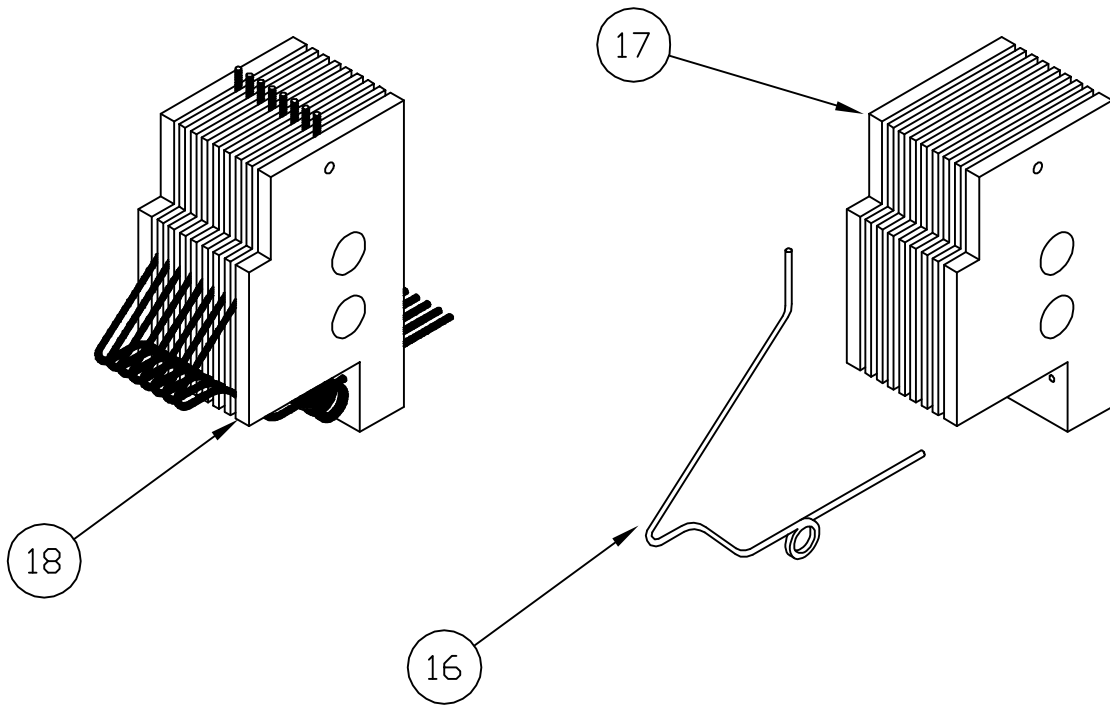

MICRO-SWITCH ASSEMBLY

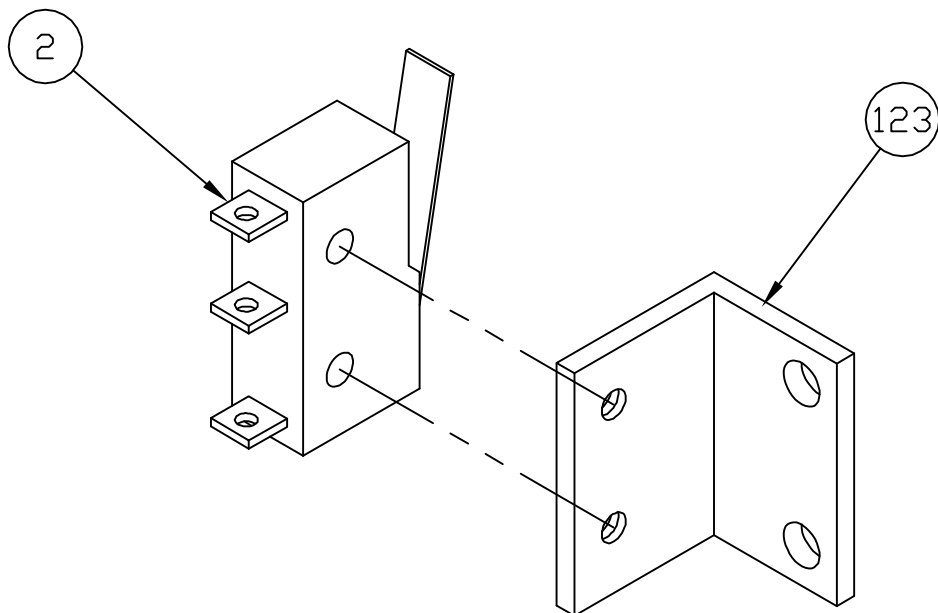

CONTROLLER AND CIRCUITS

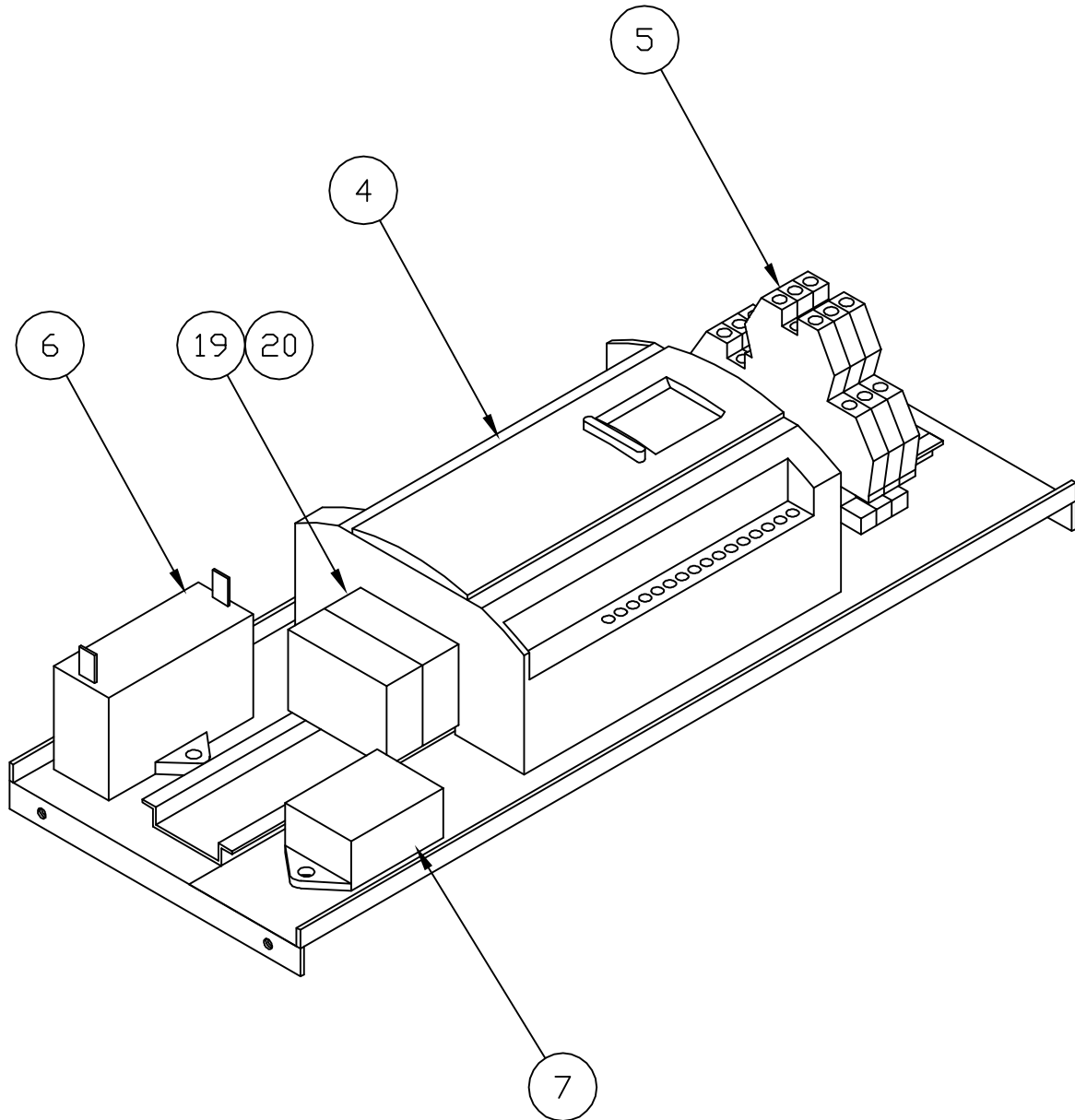

SPA-100 SPARE TOOLING

Suggested Spare tooling for the SPA-100 machine is as follows:

- A. **One** each machine – 901306 micro switch
- B. **Two** each machine - 902300 micro switch
- C. **One** pair of contact punches on most used product
8-position 901053 contact driver

TROUBLE SHOOTING TIPS

Motor will not run

Check the relays in rear of machine. They may have come loose during shipment.

Ram cycling continuously up and down or drifting

Check the micro switch at the top of machine for proper placement and/or not working. Check break pac relay to ensure it is working properly. (see adjustment notes below)

No cycle on auto

Micro switch in nest may be faulty, or may be pushed too far. There maybe lint build-up. Check both nests.

Testing displaying error: product looks fine

Tooling may be out of adjustment, causing plastic skiving of the ribs which insulates the test probes from the contacts.

If test leads don't have enough bend on the front, they may not snap down between the ribs to make continuity with the contacts in the plug.

MAINTENANCE FOR SPA-100

1. Use a soft brush to lightly remove any debris that may build up on machine. Always keep the nest cavity clean.
2. Grease machine at the top, once a month or every 500 hours of service. With the machine off, take a cloth underneath the ram and remove excess grease. This should be done from time to time between greasings to assure that grease does not come in contact with product.
3. When replacing tooling, store unused tooling in plastic or wax paper after being lightly sprayed with light oil. When replacing tooling lightly brush off tooling working surfaces and wipe oil clean from tooling. Do not oil the gibbs, as this will break down the grease that has been placed in them from the factory.
4. A maintenance program should be established for service on a regular basis. The amount of usage will determine whether this should be performed daily, weekly or monthly.
5. Take extra care that no chemicals remain in the nest portion of the machine when resuming production. This will prevent any possible chemical reaction.
6. Contact a service representative for any further information.

WARNING! When maintenance is being performed, please make sure power is off!

Ram adjusting procedure:

If the ram is cycling erratically or drifting down where it is difficult to insert a plug into the nest, follow these instructions.

When the ram drops down to low after the plugs have been tested and then removed from the nest, the micro switch is a bit out of adjustment.

- Loosen the nut (item #72) and turn the screw counter clockwise about 1/8th of a turn, then tighten the nut.

If this doesn't eliminate the problem repeat the process.

(this could also be done if the ram runs up and down without stopping.) but turn screw clockwise.

If the ram reaches the top and doesn't come down properly to its initial starting point an adjustment the opposite direction is necessary (counterclockwise).

SPA-100 SPARE PARTS - ELECTRICAL ITEMS

<u>ITEM #</u>	<u>PART #</u>	<u>DESCRIPTION</u>
1	901306	Micro Switch SS-SGL
2	902300	Micro Switch (Radio Shack)
3	902301	Brothers Gear Motor
4	902302	Mitubishi Controller
5	902303	Terminal Block
6	902304	Capacitor
7	902305	Break Rectifier
8	902306	Reverse Switch
9	902307	Power Switch
10	901370	Rocker Switch (DS-308)
11	901371	Fuse Holder
12	901372	Midget fuse
13	901373	Power Cord
14	902308	Power Cord Grommet
15	901375	20 Pin Header-Right Angle
16	902309	Test Wires
17	902310	Test Blocks
18	902311	Test Block Assembly
19	902312	Relay
20	902313	Socket

SPA-100 SPARE TERMINATING PUNCHES

<u>ITEM #</u>	<u>PART #</u>	<u>DESCRIPTION</u>
26	901053	CD-8 (8 Position Contact Driver)
27	901057	CB-8/10 (8 & 10 Position Conductor Bar Punch)
28	901059	LC-8/10 (8 & 10 Position Latch Crimp Punch)

SPA-100 SPARE NESTS, ACCESSORIES & HARDWARE

<u>ITEM #</u>	<u>PART #</u>	<u>DESCRIPTION</u>
51	901112	8/10 Position Nest – Left Hand
52	901113	8/10 Position Nest – Right Hand
53	901114	
54	901115	
55	901116	
56	901117	
57	901125	Ball Vilers for Plug Nests
58	902100	Ground Screws for Plug Nests
59	902101	Springs on Testers
60	902102	Punch Adjusting Screw & Nut
61	902103	Set Screws for Punches
62	902104	Bearing Tester
63	901348	Bearing Motor
64	902105	Adjustment Screw & Nut
65	902106	Vertical Adjustment Screw
66	902107	Horizontal Adjustment Screw
67	902108	Test Block Screw & Nuts
68	902109	Test Block Slide Pin
69	902110	#10-32 SHCS
70	902111	Dowel Pin for Spring

SPA-100 MACHINE COMPONENTS

<u>ITEM #</u>	<u>PART #</u>	<u>DESCRIPTION</u>
101	902325	Machine Base
102	902326	Upright Tool Slide
103	902327	Base Cover
104	902328	Front Panel
105	902329	Rear Panel
106	902330	Bottom Mounting Plate
107	902331	Spacer Block
108	902332	Nest Holder
109	902333	Left Plug Stop
110	902334	Right Plug Stop
111	902334	Guide Rail
112	902335	Slide Block
113	901353	Guide Block
114	901318	Brass Ram Bushing
115	902336	Eccentric Shaft
116	902337	Key
117	902338	Slide Stop
118	902339	Adjustment Block
119	902340	Punch Holder RH
120	902341	Punch Holder LH
121	902342	Pivot Bracket
122	902343	Tester Pivot Plate
123	902344	Micro Switch Bracket
124	902345	Guard Spacer
125	902346	Guard Spacer
126	902347	Main Machine Guard
127	902349	Cam Plate
128	902350	Main Machine Spacer for Guard
129	902351	Stop Plate

STEP 1: Preparing your test setup

1. Set the option **LOCK ON LEARN** to **OFF**.

NOTE: If you do not know how to set options, see "Selecting options and changing settings."

2. Turn off analyzer:
(1) install adapters
(2) replace cover plate
(3) attach sample cable.

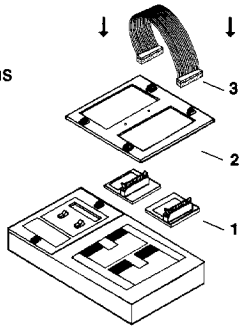

3. Turn on analyzer and wait for the display to prompt "Please Verify."

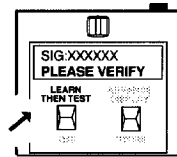

To verify the cable, press the Advance Display switch to:
1. Identify Adapters
2. Scroll through wire list

4. Remove the sample cable.

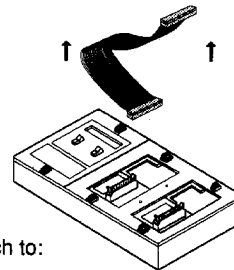

5. Display will prompt "Ready to Test."

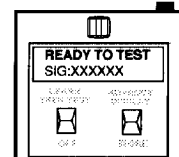

STEP 2: Documenting cables

1. Prepare test setup and learn cable as in Step 1.

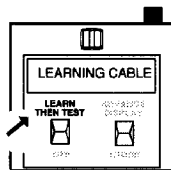

2. When the analyzer prompts "Please Verify," press the Advance/Display switch to document.

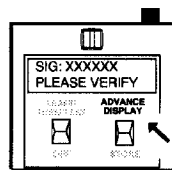

Option A: With a printer
If you have a printer connected to the analyzer, documentation prints automatically.

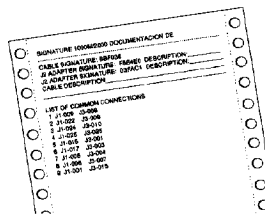

Option B: Without a printer
Press Advance Display to prompt wire list. Transcribe prompts to a blank documentation form.

**1000M/2000
Documentation Form**

Signature: _____

J1 Adapter: Description _____

J2 Adapter: Description _____

NET _____

1. _____

2. _____

3. _____

4. _____

STEP 3: Testing cables

1. Prepare test setup and verify cable as in Steps 1 and 2.

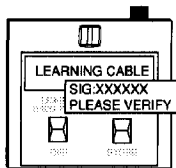

2. Remove cable used in preparing setup.

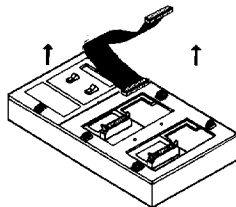

3. When display prompts "Ready to Test," attach new cable.

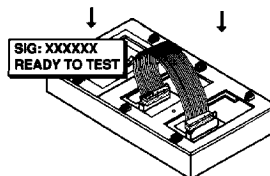

4. If cable is good, remove it and attach another one.

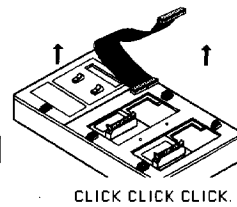

CLICK CLICK CLICK...

5. If cable is bad, press Advance Display to locate errors.

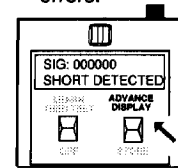

Selecting options and changing settings

1. Press and hold in the Advance Display switch as . . .

2. . . . you press the Learn Then Test switch to turn on analyzer.

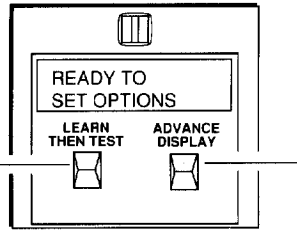

3. Then release the Advance Display switch. The analyzer prompts the first option.

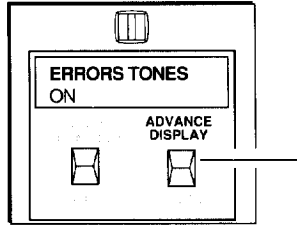

4. Press Store to change the option setting.

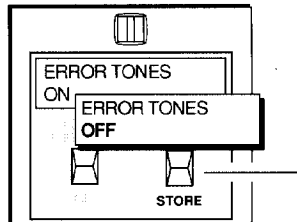

5. Press Advance Display to see next option.

Memory button

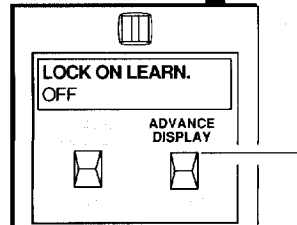

NOTE: Holding in the Memory button as you press the Advance Display switch reverses the order that options and settings appear.

Name of Option

Explanation

ERROR TONES
ON

- When the analyzer detects errors it emits a series of sharp beeps. This option lets you turn off the beeps to do rework or guided assembly.

LOCK ON LEARN
OFF

- When set to ON, the analyzer always uses the last learned wire list for testing. This allows you to learn a cable, then lock the test so it will only test that cable.

TEST DELAY
MEDIUM

- With this option you change the analyzer's test speed for testing short, medium, and long cables.

IGNORE UNUSED
OFF

- When set to ON, the analyzer only scans those positions that have connector adapters installed in them and ignores the unused positions. When set to OFF, the analyzer scans all pins.

SORTED WIRE LIST
ON

- When set to ON, this option orders pins from lowest to highest in a net. When set to OFF, pin order within a net follows the wire position of the connector.

COUNT ALL CABLES
ON

- When set to ON, printouts show the total number of cables tested for a sample cable since it was learned. When set to OFF, the printout shows only the number of good cables tested.

AUTO PRINT
ON

- When set to ON, a line prints out after each test indicating if the cable is good or bad. When set to OFF, the analyzer only prompts in the display if an assembly is good or bad.

Interpreting the analyzer's display

Display	Condition	Comment
SIG:XXXXXX GOOD CABLE	Good cable	<ul style="list-style-type: none"> Wire list matches that of cable used for test setup. The cable is good. Remove cable and test another one.
SIG:000000 OPEN DETECTED	Open	<ul style="list-style-type: none"> Wire list does not match that of cable used for test setup. The analyzer detects a missing connection. Press Advance Display to prompt the net(s) with the error(s).
SIG:000000 SHORT DETECTED	Short	<ul style="list-style-type: none"> Wire list does not match that of cable used for test setup. The analyzer detects shorted points. Press Advance Display to prompt the net(s) with the error(s).
SIG:000000 ERRORS	Errors	<ul style="list-style-type: none"> "ERRORS" indicates a combination of shorts and opens. Press Advance Display to prompt all errors.

Interpreting an error list

Below is an example of a typical error list created by a printer connected to the analyzer. If you don't have a printer connected to your analyzer, you can still create an error list by pressing the Advance Display switch each time the analyzer detects an error. You then transcribe the information prompted in the analyzer's display.

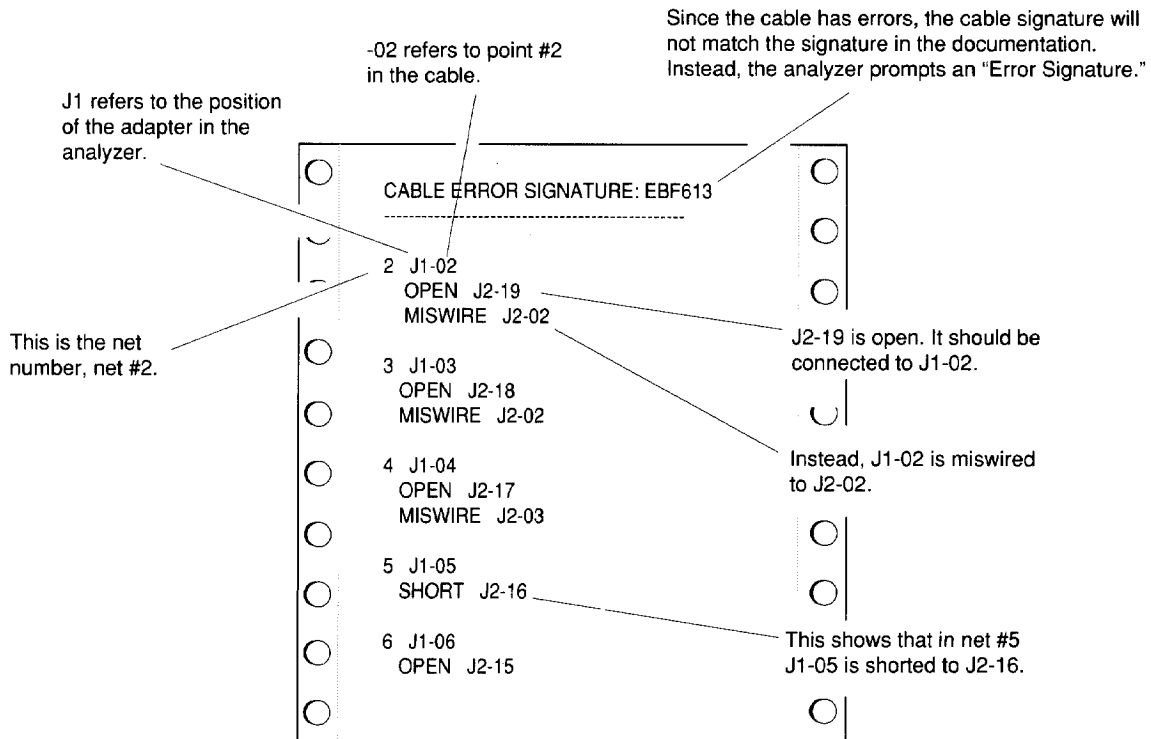

Using the analyzer's memory

Storing wire lists

1. Remove cable. Display will prompt "Ready to Test."

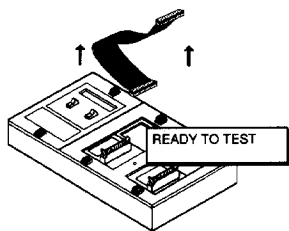

2. Press in and hold Memory button as you press Advance Display.

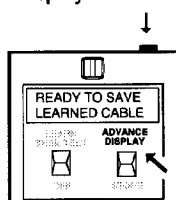

3. Continue pressing Advance Display to scroll through memory locations.

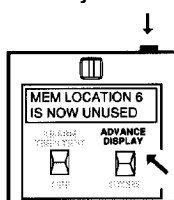

4. Press Store to store wire list in unused location.

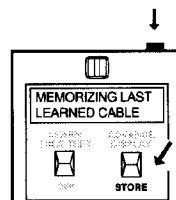

5. Release Memory button.

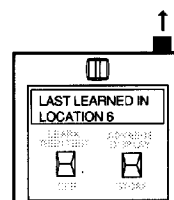

Retrieving wire lists

1. Remove any cables, then set the option *LOCK ON LEARN* to OFF.

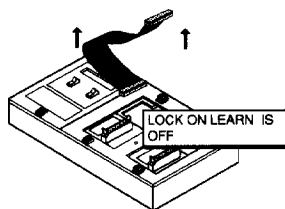

2. Press and hold Memory button as you turn on analyzer.

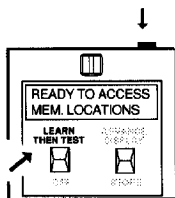

3. Press Advance Display to select wire list in memory.

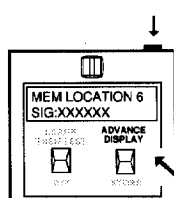

4. Release Memory button.

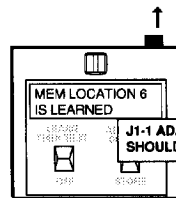

NOTE: If the wrong adapters are installed, the analyzer prompts correct ones.

Deleting wire lists

1. Remove any cables, then set the option *LOCK ON LEARN* to OFF.

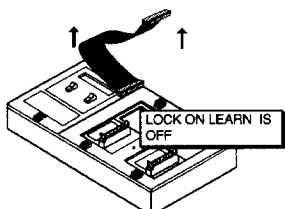

2. Press and hold Memory button as you turn on analyzer.

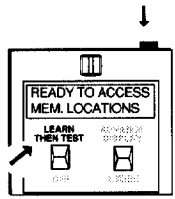

3. Press Advance Display to select wire list in memory.

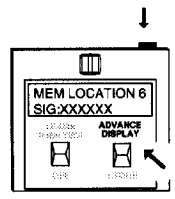

4. Press Store and hold as you release Memory button.

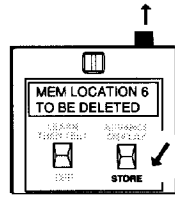

5. Release Store.

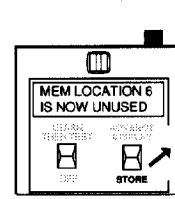

Version 1.0
 Copyright 1992
 Cirris Systems Corp.
 1991 Parkway Blvd.
 SLC, Utah 84119
 801-973-4600

Printed in the U.S.A.