

Sentinel® Connector Systems Inc.

1953 Stanton Street

York, Pa. 17404

PART NO.: 111S08080095HA4

- * EIGHT CONDUCTOR MODULAR PLUG
- * FOR HIGH SPEED APPLICATION
- * FOR CONDUCTORS WITH AN O.D. RANGE OF .037/.042
- * USE FOR STRANDED CONDUCTORS
- * FOR CAT 6 AND 6A PATCH CORD APPLICATIONS
- * SHIELDED VERSION MODULAR PLUG
- * DESIGNED TO BE USED WITH SENTINEL COMPATABLE LOAD BARS

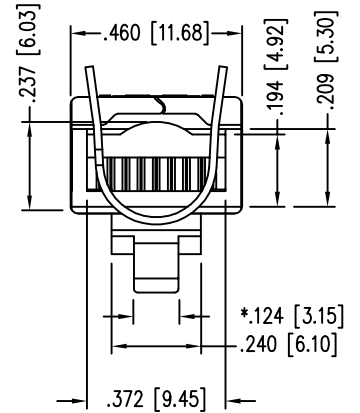
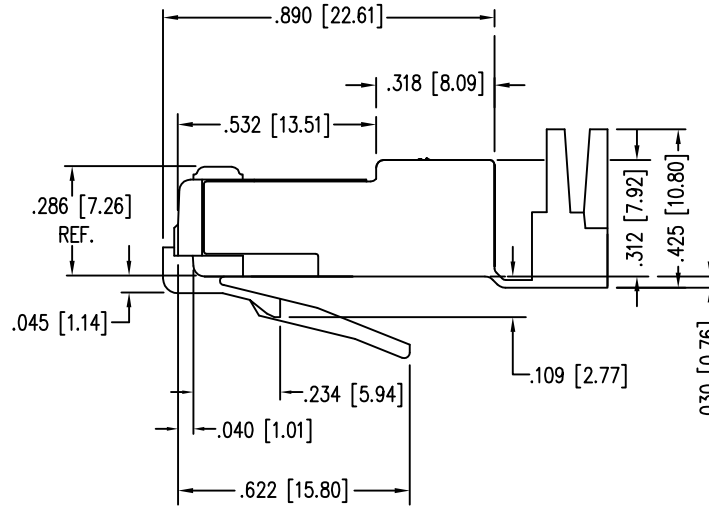
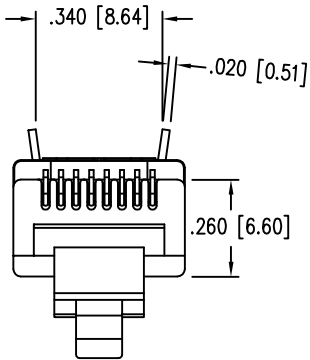
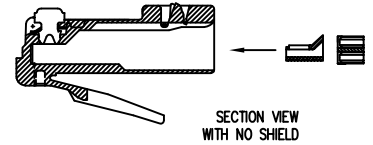
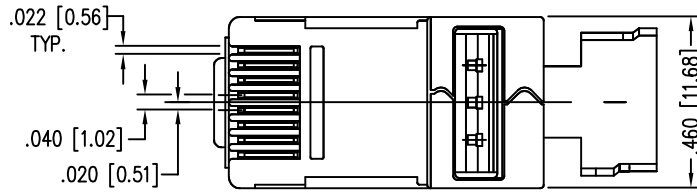
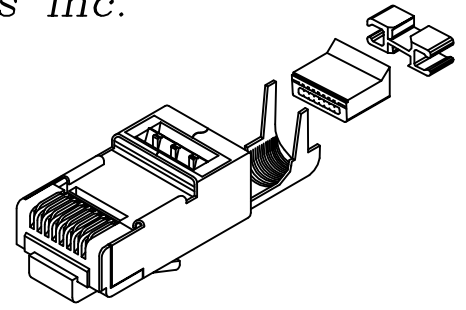

"PATENTED"

SPECIFICATIONS :

PERFORMANCE:

MEETS OR EXCEEDS CATEGORY 6 ANSI/EIA 568-C.2
PERFORMANCE TUNED TO CABLES MEETING CATEGORY 6 SPECIFICATIONS.

CONTACT MATERIAL:

PHOSPHOR BRONZE - .012 THK

CONTACT PLATING:

50 MICRO-INCH : OTHER PLATING OPTIONS AVAILABLE
SELECTIVE 24 CARAT HARD GOLD PLATE IN CONTACT AREA
OVER 100 MICRO-INCH MINIMUM NICKEL PLATE
PER CURRENT SELECTIVE GOLD PLATING REQUIREMENTS.

PLUG MATERIAL:

POLYCARBONATE

SHIELD MATERIAL:

.012 THK (.020 WHERE NOTED) CDA-260 1/4 HARD BRASS

SHIELD PLATING:

100% TIN, 100-150 MICRO-INCH TIN PLATED

PLUG TOLERANCES AND DIMENSIONS:

* COMPLIES WITH ANSI/TIA-1096-A REQUIREMENTS

FLAME AUTO EXTINGUISH

94-V0 - File# E188111

OPERATION TEMPERATURE:

-40°C TO +85°C

INSERTION/EXTRACTION LIFE:

1000 CYCLES

CONTACT RESISTANCE:

10 MILLOHMS MAX.

CURRENT/VOLTAGE:

30 VAC/42 VDC AT 1.5 AMPS

(RoHS COMPLIANT)

* FORMER COMPLIANCE, FCC PART 68.500

