

Sentinel® Connector Systems Inc.

1953 Stanton Street

York, Pa. 17404

PART NO.: 102-080810-14

- * EIGHT CONDUCTOR MODULAR PLUG
- * RADIUSSED OPENING FOR ROUND CABLE
- * FOR CONDUCTORS WITH MAXIMUM O.D. OF .031
- * FOR STRANDED WIRE APPLICATIONS
- * USES .012 THICK CONTACT

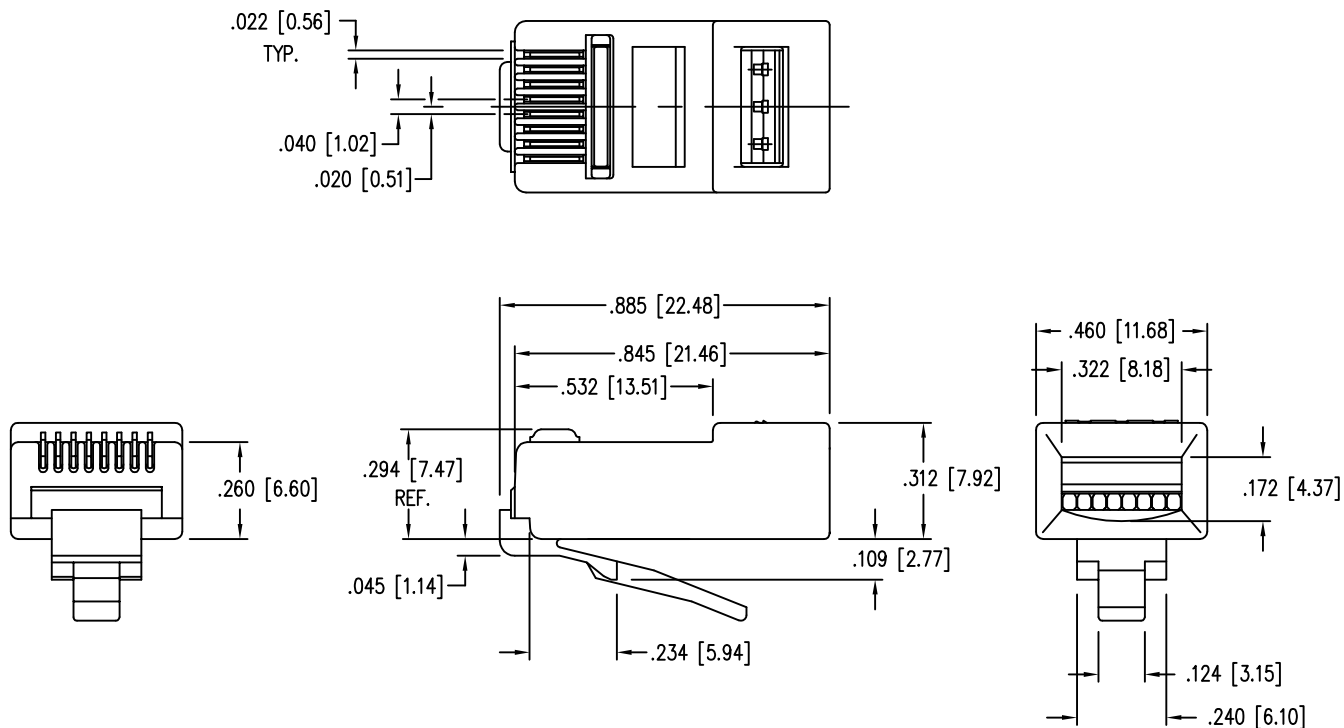

SPECIFICATIONS :

CONTACT MATERIAL: PHOSPHOR BRONZE - .012 THK
 CONTACT PLATING: 50 MICRO-INCH SELECTIVE GOLD PLATE
 IN CONTACT AREA OVER 100 MICRO-INCH
 MINIMUM NICKEL PLATING.
 OTHER PLATING THICKNESSES AVAILABLE.

PLUG MATERIAL: POLYCARBONATE

PLUG TOLERANCES AND DIMENSIONS: * COMPLIES WITH ANSI/TIA-1096-A REQUIREMENTS

U.L. RECOGNIZED File# E188111
 FLAME AUTO EXTINGUISH 94-V0

OPERATION TEMPERATURE: -40°C TO +85°C

INSERTION/EXTRACTION LIFE: 1000 CYCLES

CONTACT RESISTANCE: 10 MILLOHMS MAX.

CURRENT/VOLTAGE: 30 VAC/42 VDC AT 1.5 AMPS

(RoHS COMPLIANT)

* FORMER COMPLIANCE, FCC PART 68.500

PRODUCT LINE — SIZE — OPENING — FUTURE
 PART NO. = 102-080810-14XX
 SERIES — # CONTACTS — KEY — CONTACT/PLATING